

**ACCEPTABLE MANAGEMENT
PRACTICES FOR MAINTAINING**

Water Quality

**ON LOGGING JOBS
IN VERMONT**

9h Printing 2006

Effective Date August 15, 1987
Copies Available in Print or On-line
www.vfpr.org/resource/for_forres_acceptman.cfm

Department of Forests, Parks, and Recreation
103 S. Main St., Bldg. 10 South
Waterbury, VT 05671-0602
www.vtfpr.org

This document available upon request in
Braille, Large Print, and Audio Cassette
VT TDD Relay 1-800-253-0191

Printed on Recycled Paper (08/06 vga)

CONTENTS

Introduction.....	4
Acceptable Management Practices.....	8
Section I: Practices To Be Applied	
During Logging.....	9
Truck Roads.....	9
Skid Trails.....	18
Surface Water and Stream Crossings.....	22
Protective Strips.....	29
Log Landings.....	31
Section II: Practices To Be Applied	
After Logging.....	33
Truck Roads.....	33
Skid Trails.....	35
Surface Water and Stream Crossings.....	35
Log Landings.....	36
Summary Chart for Drainage Devices.....	37
Assistance.....	38
Logging Job Complaints.....	39

References.....	40
Appendix I – Vermont Laws.....	42
A. Laws and Regulations Affecting Logging Operations.....	42
B. Forest Property Tax Laws.....	48

Introduction

In 1986, the Legislature passed amendments to Vermont's Water Quality Statutes which declared that "it is the policy of the state to seek over the long-term to upgrade the quality of waters and to reduce existing risks to water quality."

According to the revised law, permits are now required for discharges of "any waste, substance or material into the waters of the state." However, individual permits are not required for those discharges caused by logging operations if "acceptable management practices" (AMP's) are in place; that is, if loggers and landowners have followed proper measures to protect the waters of the state.

This booklet describes the AMP's for maintaining water quality on logging jobs in Vermont. These AMP's are intended to prevent "discharges"; that is mud, petroleum products and woody debris, from getting into our streams, ponds, lakes and rivers. They are also meant to maintain natural water temperatures by requiring that trees be left along streams and other water bodies.

The AMP's have the force of law and violations can be costly, so it is important to understand the conditions under which they can be enforced. These conditions are as follows:

1. A violation occurs only if there is a discharge. If no discharge occurs, the logger or landowner cannot be fined or prosecuted for not having the AMP's in place.
2. If there is a discharge and the AMP's are properly in place, there is no violation.
3. If there is a discharge and the AMP's have not been followed, there is a violation.
4. "Slash", that is, branches, bark or pieces of wood in a stream or other water body are automatically considered a violation, except for temporary "brushing in" of streams during frozen conditions.
5. In cases where for some reason the AMP's cannot be applied, and it is uncertain that discharges can then be prevented, there is a legal alternative: a landowner or logger can apply to the Department of Environmental Conservation for a discharge permit. It is likely, however, that permits will be granted only in extraordinary circumstances.

In summary, a logger or landowner is liable to legal action only when a discharge takes place and either no permit has been obtained or the AMP's have not been followed. Thus, the AMP's are not only basic to sound forestry, they also legally protect the logger or landowner during and after timber harvesting.

Loggers and landowners who cause discharges of sediment or other pollution from logging jobs and who have not followed either AMP's or conditions of a permit may be subject to enforcement action,

penalties or both. The penalties for significant water pollution, including slash and sedimentation, as established in Vermont's water quality law, could include the removal of wastes and restoration of water quality at the expense of the logger or landowner, compensation for damages, reimbursement of any government expenses caused by the discharge, penalties of up to \$10,000 a day for each day of violation or fines of up to \$25,000 and imprisonment of not more than six months. Excerpts of Vermont's new water quality law amendments relative to enforcement and penalties are in Appendix 1.

Landowners are ultimately responsible for application of these AMP's. However, a good timber sale contract will transfer this responsibility to the logger during the harvesting operation. Landowners are responsible for maintaining erosion control devices after a logging operation is completed.

Both Vermont's old water quality law and the new amendments make the cost of polluting substantial. There are other costs besides fines and legal fees, however: soil erosion from careless logging make landowners reluctant to sell if they think their land will be damaged; equipment depreciates faster because of the additional wear and tear caused by traveling through mud and over difficult terrain; siltation can harm fish by smothering eggs and aquatic biota and can generally decrease the value of the aquatic habitat.

Regular inspection of all roads and prompt corrective and preventive action to avoid erosion and pollution problems is part of a high quality logging operation. Soil erosion from logging activity can be controlled by applying AMP's in this handbook during and after logging.

When questions arise concerning the proper application of these practices, technical assistance is available from the Department of Forests, Parks and Recreation (See page 38).

Acceptable Management Practices

The AMP's are shown in larger print and underlined. Each is followed by supplementary information meant to assist loggers in applying the practices. The underlined sections are the enforceable standards which will be applied to determine a violation if a discharge from a logging job occurs. If it is determined that a violation has occurred due to failure to observe the AMP's (or the conditions of a permit), the logger or landowner will be considered in violation of Vermont's water quality laws.

The AMP's are the proper method for the control and dispersal of water collecting on logging roads, skid trails and log landings to minimize erosion and reduce sediment and temperature changes in streams. Planning before the job starts will reduce the problems which might occur and prevent costly repairs after the fact.

EXTREME CAUTION should be applied when logging during the spring wet season or during wet weather conditions. The erosion potential is highest during these times. Muddy logging roads will also increase equipment maintenance costs and decrease equipment life.

Practices to be Applied During Logging

Truck Roads

1. Steep pitches (greater than 10% on permanent truck roads shall not exceed 300 feet in length.

Truck roads take logs from a landing; skid trails bring logs to a landing.

A permanent road is defined as a road that will be continuously passable as access to a parcel of land. Bridges and culverts on permanent roads will usually be left in place and regularly maintained. A temporary road is defined as a road constructed for purposes of one-time access to a log landing which will receive minimal or no use after the logging operation. Bridges and culverts on temporary roads will be removed at the conclusion of the logging operation and stream banks will be permanently stabilized.

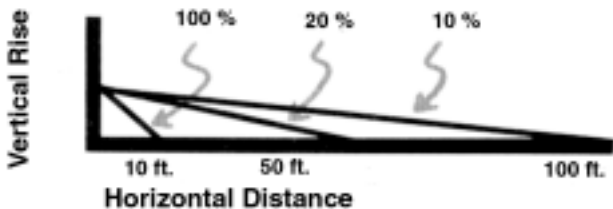

Figure 1: Slope Percent. Slope percent is calculated by dividing the rise or elevation by the run or horizontal distance. For example, a slope that gains 10 feet of elevation over 100 feet of horizontal distance is a 10 percent slope.

- Walk the area to be logged to determine the best access route(s).

- Use old roads when acceptably located and of moderate grades as defined above.

- Avoid rock outcrops, ledges, swampy places and other features which will present difficult construction problems.

- Road locations should be flagged, cleared and graded before logging begins.

- Lay out the routes such that proper filter strips along streams can easily be provided and stream crossings will not involve major stream disturbances.

2. Road surfaces shall be adequately drained. Ditches shall be used to divert water away from the road surface. Where it is necessary to prevent an excessive accumulation of ditch water volume or to bring water under the road on road grades greater than 10 percent, pole culverts or metal culverts shall be used. Broad based dips can be used instead of culverts to relieve ditches or to bring water across the road when road grades are less than 10 percent. Drainage structures shall be installed with a gradient (slope from the uphill side of the structure to the outlet) of at least 4 degrees when ledge and rock permit and kept free of debris. Drainage structures shall be spaced according to Table I where conditions permit.

**Table 1: Recommended Distances Between
Drainage Structures on Logging Roads**
Feet

Road Grade (percent)	Distance Between Waterbars	Distance Between Culverts	Distance Between Turnups, Dips & Pole Culverts
1	400	450	500
2	250	300	300
5	135	200	180
10	80	140	140
15	60	130	130
20	45	120	120
25	40	65	--
30	35	60	--
40	30	50	--

All drainage structures should be inspected and cleaned frequently during active logging operations.

-Pole culverts (Figure 2) are an inexpensive method of draining a road surface. These culverts may be installed either before or after a major hauling use and should be spaced the same as broad-based dips. They can be constructed of cull logs or from sawn timber. If made of durable wood or treated material, these culverts will give many years of service.

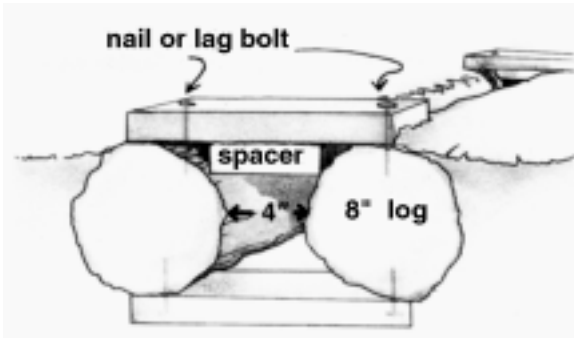

Figure 2: Proper Construction of Pole Culverts on Logging Roads.

- Broad-based dips (Figures 3 and 4) can be used where no streams cross the road and where the road grade is less than 10 percent.
- Broad-based dips are easier to maintain and more permanent than pole culverts but their proper construction requires a trained bulldozer operator. The dips should be installed before a major hauling use and should be spaced the same as pole culverts.

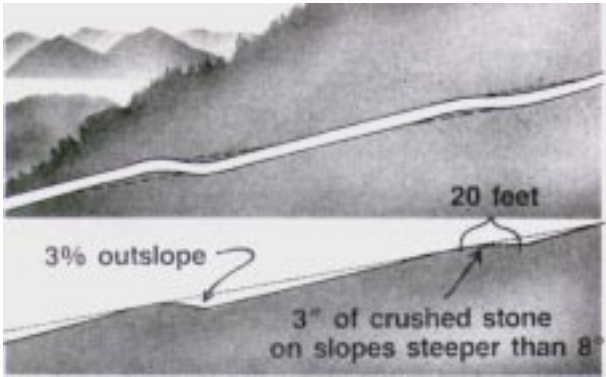

Figure 3: Diagram and Design of Broad-Based Dips on a Mountain Logging Road.

- Dips can be constructed with skidder or bulldozer by cutting a few feet out of the skid trail and bulldozing a fill area to build up grade on the lower side (Figures 3 and 4). The drainage dips are usually broad and shallow over a 20-foot section of skid trail allowing a skidder to travel over them without cutting ruts. See Table 1 for recommended distance between “dips”.
- Dips or water bars should be created by digging into soil by a dozer pushing downhill.
- Use standard drainage dips on approaches to steep declines in skid trails.

Table 2: Guide for Determining Culvert Size When Permanent and Temporary Track Roads Cross Streams.

DRAINAGE AREA - The number of acres sloping toward the stream

Well drained Soils	Shallow Soils with Frequent rock outcrops or impermeable soil conditions	Recommended pipe diameter (inches)
16	4	15
25	7	18
40	12	21
55	16	24
84	27	30
130	47	36
190	64	42
260	90	48
335	120	54
400	166	60
550	205	66
650	250	72

-Ditches should be properly stabilized (seeding, rock lining) to minimize erosion.

-Pipe culverts (Figure 5) are used to move water under the road before it gains sufficient flow to erode the ditch on the uphill side of the road. This is the most expensive method of cross road drainage and

should be used where heavy road use is anticipated during or after logging. Culverts should be installed at a 30 degree angle down grade, should angle downhill at least 4 degrees when ledge and rock permit for self-cleaning and should outlet onto stone rip-rap, gravel or logs.

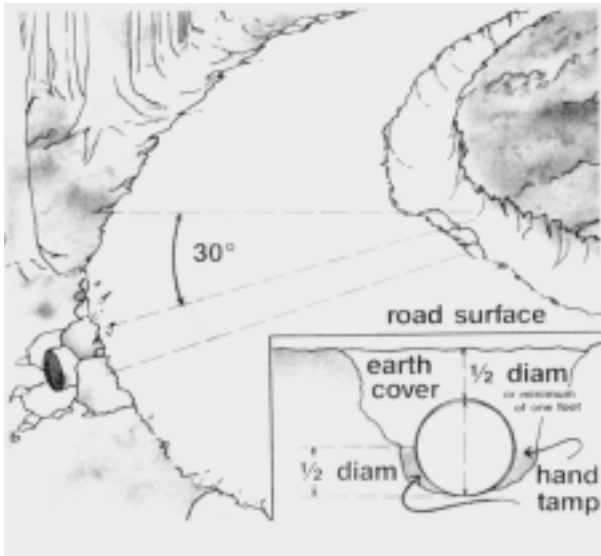

Figure 5: Design and Installation of Pipe Culverts.

-When sizing culverts for temporary roads, allow for periods of high flow, such as spring runoff or cloud-bursts (Table 2).

-A minimum of 12 inches of soil should be used to cover culverts.

-When constructing roads on side hill locations, ditch the uphill side of the roadway to intercept surface runoff.

-Inspect and clean out ditches and culverts frequently.

-Crown up roads to provide for road surface drainage.

4. Drainage ditches shall not terminate where they will feed water directly into streams or other surface waters.

-Ditches along roads approaching water crossings should be designed to empty into a protective strip of undisturbed, vegetated land. Most often, this can be accomplished by turning ditches out into the woods. The width of the protective strip depends on the slope of the land.

Skid Trails

Skid trails bring logs to a landing; truck roads take logs from a landing.

5. Skid trails shall not go straight up a slope but proceed at a gradual angle across the slope. Short steep sections of up to 20 % grade are

permissible, but shall not exceed 300 feet in length.

- Keep skid trail grades as low as topography will allow.
- Walk the area to be logged to locate skid trails.
- Main skid trails should be flagged, cleared and graded. Trails used to bring logs from stump to the main skid trail are usually not graded and require a minimum amount of clearing.
- Lay out skid routes such that proper filter strips along streams can easily be provided and stream crossings will not involve major stream disturbances.
- Avoid stream banks, rocky places and steep grades.
- Building skid trails from the top down is easier.

6. Long straight stretches of skid trail shall be adequately drained using outslowing turnups, broad based dips (on grades of 10 percent or less), or pole culverts. Spacing of drainage structures shall be determined according to Table 1.

- Take advantage of the natural cross drainage.

- Locate skid trails on side hill locations and slightly outsloping the road surface.
- Turn-ups are constructed by turning the skid trail up the hill a few feet, then turning downhill again (Figure 6). By reversing the grade in this way, water will run off the downhill side of the skid trail.

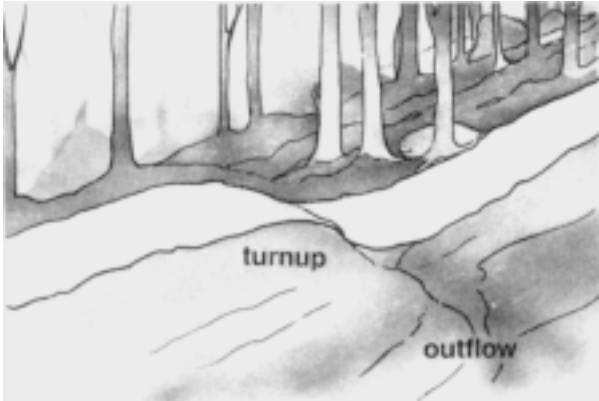

Figure 6: Turn-ups. Cross drainage can be obtained by turning the skid trail up the hill a few feet then turning downhill again.

- Broad-based drainage dips are commonly used for skid trail drainage. As with truck roads, dips can be used where no streams cross the skid trail and where the trail grade is less than 10 percent.

Dips are fully described on pages 11-21.

-Turn-ups are commonly applied for skid trails rather than roads and the distance of the turn-up is very short compared to a broad based dip.

7. Silt fencing, hay bale erosion checks or water diversions shall be used to prevent sediment from skid trails from entering streams and other surface waters.

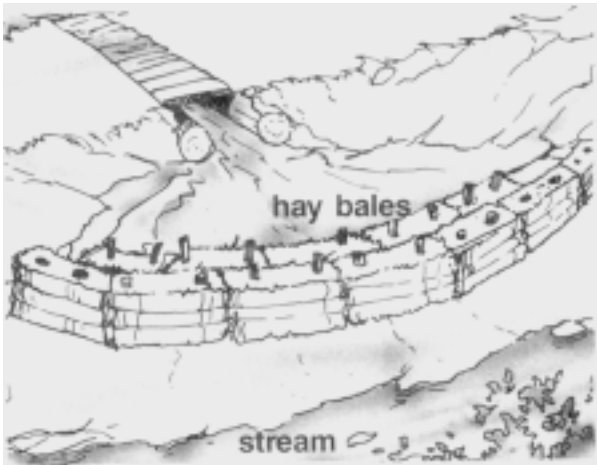

Figure 7: Hay Bale Erosion Check.

-Hay bales should be embedded into the ground using stakes.

-Hay bales should be overlapped to increase their effectiveness to intercept runoff and to reduce the potential for movement.

-Hay bale erosion checks may not be necessary during frozen, stable winter conditions.

Surface Water and Stream Crossings

8. Streams and all bodies of water shall be kept free of slash and other logging debris.

-It is illegal to discharge any waste into the waters of the state, therefore, the deposition of slash in a stream constitutes a “discharge”.

-Slash in a stream or other surface waters constitutes a legal violation **regardless of whether it causes erosion or sedimentation.**

-Slash left in streams may cause a blockage with potential for serious erosion and flooding.

-Temporary “brushing-in” of streams is allowed during frozen winter conditions on skid trails (see AMP #9 and Figure 10) provided all slash is removed.

9. Truck road crossings of all permanent streams shall be over a bridge or culvert. Streams may be forded by skid trails only where streambeds have stable beds and stable, gradual approaches (gravel or ledge). Streams may also be crossed by brushing-in during frozen winter conditions but all brushed-in material shall be removed from the stream channel when skid trail use has been completed or before spring runoff, whichever occurs first.

-Bridge crossings are preferable to culverts since there is less disturbance of the stream channel.

-Plan roads and skid trails to reduce crossings to the absolute minimum.

-Bridges and culverts prevent erosion and stream siltation and reduce the amount of gasoline, oil and grease which are often washed off the wheels and under-carriage of vehicles when crossing streams.

-Culvert size selection and bridge design should be based on the size (acres) of the drainage area that they serve and should be able to handle the largest potential stream flows. Undersized bridges or culverts may wash out during spring runoff. See

Table 2 for the appropriate culvert size based on drainage area served.

- Bridge crossings should be located where the stream channel is straight with an unobstructed flow of water.

- The roadway approaching the stream should be reasonably level for a distance of 50 feet on each side of a bridge, culvert or ford crossing.

- A simple skid road bridge design is the header bridge shown in Figure 8. This type of bridge can be constructed from cull logs and low-grade timber.

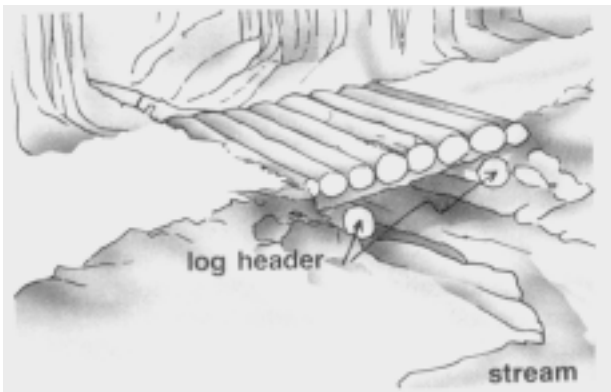

Figure 8: Design of Simple Header Bridge

-Fords are acceptable as skid trail crossings when streams have stable beds and approaches (i.e. gravel or ledge).

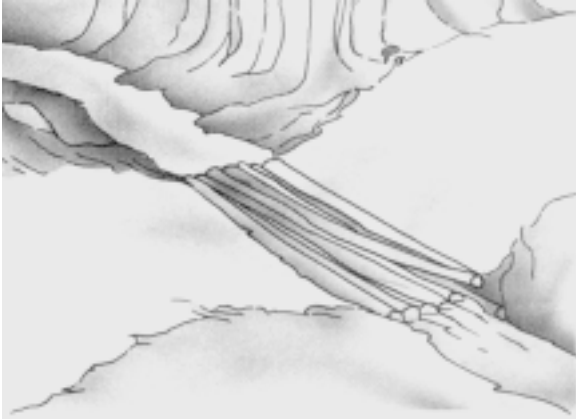

Figure 9: Design of Poled Ford Stream Crossing.

-Temporary crossing of small brooks may be accomplished by placing poles or cull logs side by side in the streambed (Figure 9). The logs must be removed immediately after use.

-Poled fords should be inspected regularly to make sure the stream is not becoming turbid at the crossing.

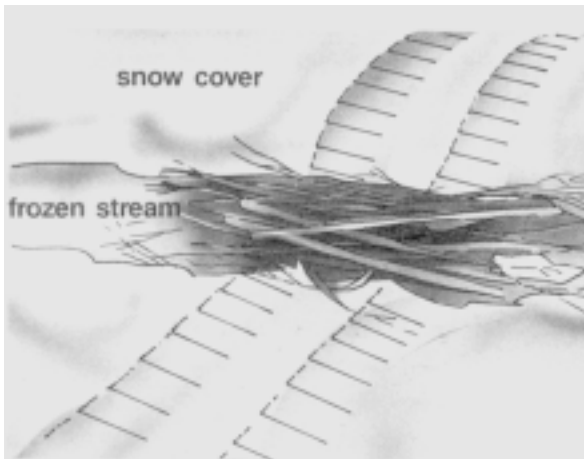

Figure 10: “Brushing-In” a Streambed During Frozen Winter Conditions

- “Brushing-in” should be restricted to small frozen stream channels.
- Avoid sections with steep approaches.
- Avoid sections of stream channels with steep gradients.
- Remove all brush.

10. Logging activities, except for the necessary and proper construction of stream crossing structures, shall be kept out of stream channels.

-Streams, both perennial and intermittent, should be left in their natural courses.

-Placement of bridges or culverts that require work in the stream should be done when the water is low.

-Work should be done in as short a period as possible.

11. Turn-ups or broad-based dips shall be used before a truck road or skid trail crosses a stream.

-Turn-ups or broad-based dips should be installed at the bottom of slopes approaching a stream crossing and should be at least 25 feet from the drainage structure to provide for a protective strip between the road or trail and the stream bank.

12. Areas of exposed soil within 25 feet of streams must be seeded and mulched with application rates as shown in Table 3.

-Seeding and mulching should be done as soon as possible to minimize potential for erosion.

-Seeding and mulching should be done during seasons and during weather conditions favorable to seed germination.

Table 3: Methods of Seeding and Mulching Logging Roads, Log Landings and Skid Trails.

Temporary Cover

Material	Rate of Application	Recommended Time of Application
(A) Hay Mulch Only	60 bales/acre	Any time
(B) Domestic Ryegrass	20 lbs./acre	Fall (for spring growth)

OR

Permanent Cover

Material	Rate of Application	Recommended Time of Application
(A) Soil Conservation Mix* <i>Creeping Red Fescue</i> 35% <i>Redtop</i> 6% <i>Kentucky Bluegrass</i> 24% <i>Perennial Ryegrass</i> 18% <i>Annual Ryegrass</i> 20% <i>White Clover</i> 5%	42 lbs./acre	April 15 – June 15 or Aug. 1 – Sept. 15

*Premixed and available at most seed distributors.

Permanent Cover (cont.)

Material	Rate of Application	Recommended Time of Application
(B) Critical Area	42 lbs./acre	April 15 – June 15 or Aug. 1 – Sept. 15
Mix — <i>Creeping Red Fescue</i> 48% <i>Redtop</i> 4% <i>Tall Fescue</i> 48%		

Site Preparation for Permanent Cover

- Lime should be spread at rate of 2 tons/acre.
- Fertilizer should be a mixture of 10-10-10 applied rate of 240 lbs./acre.
- Mulch at 60 bales/acre.

13. Stream crossings shall be made at right angles where possible.

Protective Strips

14. Except for necessary construction of stream crossings, a protective strip shall be left along streams and other bodies of water in which only light thinning or selection harvesting can occur so that breaks made in the canopy are minimal and a continuous cover is maintained. Log

transport machinery must remain outside a 25 foot margin along the stream or water body. Including this 25 foot margin, the width of the protective strip shall be according to Table 4.

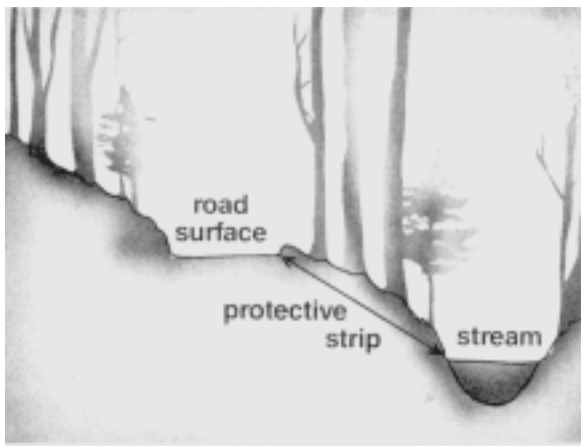

Figure 11: Protective Strip. A protective strip prevents sediment from reaching streams and maintains shade and stream bank stability.

Table 4: Protective Strip Width Guide

Slope of Land Between Roads or Landings and Stream banks or Lake Shores (percent)**	Width of Strip Between Roads or Landings and Stream (Feet Along Surface of Ground)
0-10	50
1-20	70
21-30	90
31-40*	110

*Add 20 feet for each additional 10 percent side slope.

**See Slope Chart (Figure 1).

Log Landings

15. Log landings shall be located on level or gently sloping, stable ground.

-Greater latitude exists in the location of landings during the stable conditions that exist in the frozen winter season.

-Locate log landings away from low or poorly drained areas.

-Landings should be sized to the minimum required for the acres to be cut, the equipment used and the diversity of products produced.

16. Landings shall not be located in protective strips. The width of the protective strip shall be in accordance with Table 4.

-Careful location of log landings will protect water quality and improve operating conditions for the logger.

-Divert upslope drainage from skid roads around landing area.

17. Silt fencing, hay bale erosion checks or water diversions shall be used to prevent sediment from landings from entering streams and other surface waters.

Practices To Be Applied After Logging

It is critical to leave harvested forest land in a condition that minimizes problems in the future. Application of these practices will provide long-term protection of the water.

These protective measures are to be taken before equipment is removed from the logging site.

Landowners are responsible for maintaining erosion control devices after a logging operation is completed.

Truck Roads

18. Water bars (Figure 12) on temporary roads shall be properly installed at intervals shown in Table 1. They shall be at least 8 inches deep and installed with a 4 degree gradient when ledge and rock permit.

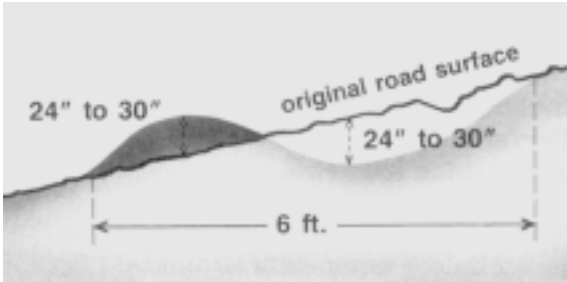

Figure 12: Water bar Design. Standard water bars shall be at least 8 inches deep. Deep water bars should be used on roads that will be closed to vehicle traffic and should be 24-30 inches deep.

- Deep water bars should be used on roads which are to be closed to vehicle traffic. Back to back water bars located at the beginning of roads will discourage use.
- Soil should be left along the lower side of the waterbar.

-Water bars should be drained at a slight outslope onto undisturbed litter or vegetation. The outslope should allow for natural drainage of water away from the road.

-If the road is to be kept open after logging, the following guidelines should be used in order to preserve effective water bars:

- (a) Keep travel to a minimum,
- (b) Use only in dry weather, and
- (c) Make periodic inspections followed up by basic maintenance.

Skid Trails

19. Ruts shall be filled and smoothed if they offer any potential for gullyng.

20. Water bars shall be installed at proper intervals according to Table 1.

-Erect barriers (i.e. boulders, felled trees, signs) to prevent off-road vehicles such as trail bikes from damaging waters.

Surface Water and Stream Crossings

21. All non-permanent structures shall be removed from streams and the channel restored. Permanent culverts left in

streams must be sized according to Table 2.

22. Following the close of an operation, all approaches to streams, between the stream and the first water diversion of either side, and all disturbed stream banks shall be stabilized and seeded and mulched at application rates according to Table 3 as soon as conditions are favorable to seed germination but no longer than one year after logging is completed.

Log Landings

23. Log landings shall be graded and water diversions installed as needed to prevent sedimentation.
24. Areas of exposed soil within the protective strip along waterways shall be stabilized by seeding and mulching with application rates as shown in Table 3.

Summary Chart for Drainage Devices

Device	Use	Location/ Spacing	Construction Specifications
Pole Culverts	Logging Roads & Skid Trails	Page 12	Figure 2
Broad-Based Dips	Logging Roads & Skid Trails Less Than 10% Grade	Page 13	Figures 3 and 4
Ditch/ Culverts	Logging Roads	Table I	Table 2 & Figure 5
Turnups	Stream Fords & Skid Trails	Page 20	Figure 6
Header Bridge	Stream Crossings		Figure 8
Fords	Stream Crossings		Figure 9
Water bars	Permanent Logging Roads and Skid Trails	Table I	Figure 12

Assistance

If you have a question or need advice in controlling soil erosion or protecting water quality on your logging job, please contact the Forestry District Office in your area and ask for the AMP Forester. Also, any complaints about logging jobs where logging slash is being left in a stream, mud is entering a stream, or where serious erosion problems are occurring should be immediately forwarded to one of the District Forestry Offices listed below for assistance.

DISTRICT FORESTRY OFFICES

Rutland and Bennington Counties
271 North Main Street, Suite 215
Rutland, VT 05701

802-786-0060

Windham and Windsor Counties
100 Mineral Street, Suite 304
Springfield, VT 05156-3168

802-885-8855

Addison, Chittenden, Franklin and Grand Isle Counties
111 West Street
Essex Junction, VT 05452-4695

802-879-6565

Caledonia, Essex and Orleans Counties
1229 Portland Street, Suite 201
St. Johnsbury, VT 05819-2099

802-751-0110

Lamoille, Orange and Washington Counties
5 Perry Street

Barre, VT 05641-4265

802-476-0170

Main FPR Office

Watershed Forester

103 S. Main St. 10 South, Waterbury

802-241-3672

FOR MORE INFORMATION

To learn more about Vermont's Watershed Forestry Program, check our Web Site at:

<http://www.vtfpr.org/watershed/index.cfm>

References

The authors of this guide have drawn freely from the following sources and these references should be considered if more information is needed:

Fisher, J. E. and Taber, D. W., *Logging Road and Skid Trail Construction, Proceeding of a Workshop*, AFRI Misc. Report No. 6, December, 1975, Applied Forestry Research Institute, Syracuse, New York.

Goodhue, Sargent, *Twelve Ways to Reduce Soil Erosion and Stream Pollution on Logging Jobs*, 1975, New Hampshire Division of Forests and Lands, Department of Resources and Economic Development, Concord, New Hampshire.

Hartung, R. E. and Kress, J. M., *Woodlands of the Northeast-Erosion and Sediment Control Guides*, 1977, USDA Soil Conservation Service, NETSC, Broomall, Pennsylvania and USFS State and Private Forestry, Upper Darby, Pennsylvania.

Hausman, R. F. and Pruett, E. W., *Permanent Logging Roads for Better Woodlot Management*, 1973, USDA Forest Service, State and Private Forestry, Upper Darby, Pennsylvania.

Kochenderfer, J. N., *Erosion Control on Logging Roads in the Appalachians*, Research Paper NE-158, 1970, USDA Northeastern Forest Experiment Station, Upper Darby, Pennsylvania.

McEvoy, Thom et. al., *Proceedings-Forest Water Quality and Erosion Control in Vermont*, 1986, School of Natural Resources, UVM, Burlington, Vermont.

Winkelaar, P., *Forest Road Location and Erosion Control on Northern New Hampshire Soils*, Extension Publication No. 2, 1971, Cooperative Extension Service, University of New Hampshire, Durham, New Hampshire.

Appendix I - Vermont Laws

Definitions

Discharge - means the placing, depositing or emission of any wastes, directly or indirectly, into the waters of the state.

Waste - means effluent, sewage or any substance or material, liquid or solid, whether or not harmful or detrimental to water.

Waters - shall include all rivers, streams, creeks, brooks, reservoirs, ponds, lakes, springs and all bodies of surface waters, artificial or natural, which are contained within, flow through or border upon the state or any portion thereof.

A. Laws and Regulations Affecting Logging Operations

Water Pollution Control:

No person shall discharge any waste, substance or material into waters of the state, nor shall any person discharge any waste, substance or material into an injection well... (From 10 V.S.A. Sec. 1259(a))

The provisions of subsections (c), (d) and (e) of this section shall not regulate accepted agricultural or silvicultural practices, as such are defined by the Commissioners of Agriculture and Forests, Parks and Recreation, respectively, after an opportunity for a public hearing... **(From 10 V.S.A. Sec. 1259(f))**

Enforcement:

(a) If the Secretary of the Agency of Natural Resources finds that any person has discharged or is discharging any waste (by not having used acceptable management practices) or that any person has failed to comply with any provisions of any order or permit issued in accordance with this chapter, the Secretary may bring suit in the Superior Court in any county where the discharge or noncompliance has occurred to enjoin the discharge and to obtain compliance. The suit shall be brought by the Attorney General in the name of the state. The court may issue a temporary injunction or order in any such proceedings and may exercise all the plenary powers available to it in addition to the power to:

- (1) enjoin future discharges;
- (2) order the design, construction, installation or operation of pollution abatement facilities or alternate waste disposal systems;
- (3) order the removal of all wastes

discharged and the restoration of water quality;

(4) fix and order compensation for any public property destroyed, damaged or injured;

(5) assess and award punitive damages;

(6) levy civil penalties not to exceed \$10,000 a day for each day of violation;

(7) order reimbursement to any agency of federal, state or local government from any person whose discharge caused governmental expenditures.

(b) The Secretary, by rule, shall define those violations which are significant, based upon the magnitude, duration, consequences and causes of the violation. When a significant violation occurs, the Secretary may initiate proceedings to compel compliance by and seek penalties from the violator. A court, upon finding that such a violation has occurred, shall order compliance and retain jurisdiction to assure that compliance schedules are met. The court also shall impose penalties.

(From 10 V.S.A. Sec. 1274)

Penalty:

(a) Any person who violates any provision of (Vermont's Water Pollution Control Law) or who fails, neglects or refuses to obey or comply with any order or the terms of any permit issued in accordance with this subchapter, shall be fined not more than

\$25,000 or be imprisoned not more than six months or both. Each violation may be a separate offense and, in the case of a continuing violation, each day's continuance may be deemed a separate offense.

(b) Any person who knowingly makes any false statement, representation or certification in an application, record, report, plan or other document filed or required to be maintained under this subchapter, or by any permit, rule, regulation or order issued under this subchapter, or who falsifies, tampers with, or knowingly renders inaccurate any monitoring device or method required to be maintained under this subchapter or by any permit, rule, regulation or order issued under this subchapter, shall upon conviction, be punished by a fine of not more than \$10,000 or by imprisonment for not more than six months or both.

(From 10 V.S.A. Sec. 1275)

Alteration of Streams:

A person shall not change, alter or modify the course, current or cross-section of any stream with a drainage area greater than ten (10) square miles either by movement, fill or by excavation of ten (10) cubic yards of fill. A person proposing to alter or modify a stream shall apply in writing to the Natural Resources Agency for a permit to do so. Penalty: Maximum fine, \$1,000. Each violation may be a

separate offense and, in the case of a continuing violation, each day's continuance thereof may be a separate offense.

(From 10 V.S.A. Secs. 1021, 1025)

Deposit of Sawmill Waste in Waters:

It shall be unlawful for a person to deposit edgings, slabs, sawdust, shavings or any other sawmill refuse in the waters of any stream, pond, reservoir or lake in the state or on the shores or banks thereof in such a manner as to be subject to being washed in the mainstream or body of water under normal high water conditions. Maximum fine shall be not more than \$100 for each offense.

(From 10 V.S.A. Sec. 1301)

Rubbish and Garbage:

A person shall not throw, dump, deposit bottles, cans, junk, paper, garbage, old automobiles, refuse of whatever nature or any noxious things on lands of others or within 300 feet of the lands of others, public or private, or into the waters of this state, or on the shores or banks thereof, or on or within view of a public highway. Logging and sawmill operations are exempt from the restrictions concerning the distance of 300 feet and visibility from a public highway. Penalty: Maximum fine \$500 or 10 days, or both.

(From 24 V.S.A. Sec. 2201)

Slash Removal:

(a) A person may cut or cause or permit to be cut forest growth only if all slash adjoining the right-of-way of any public highway or the boundary lines of woodlots owned by adjoining property owners is treated in a manner satisfactory to the town forest fire wardens.

(b) Owners or operators of timber or woodlots shall leave the main logging roads through cutover areas free from slash so that tractors may pass over these roads unobstructed in order to carry men and supplies and fire fighting equipment to fire suppression crews.

(c) If in the opinion of the town forest fire warden there is no fire hazard as a result of a cutting, he may issue, upon request, a statement relieving the operator of the conditions in this section. Penalty: Upon complaint of a fire warden, a person who violates the provisions of this section shall be fined not more than \$50 for each offense.

(From 10 V.S.A. Sec. 2648)

Logging Operations Above 2500 Feet in Elevation:

Any logging activity over 2500 feet in elevation requires an Act 250 permit.

(From 10 V.S.A. Sec. 6001, (Sec. 3), 6081)

Registration of Chip Harvesters:

The Commissioner of Forests, Parks and Recreation is authorized to license all whole tree chip harvesters, portable sawmills and other similar portable wood utilization equipment in Vermont.

(From 10 V.S.A. Sec. 2623(3))

B.Forest Property Tax Laws

(a) By town meeting vote, Vermont towns may authorize their selectmen to enter tax stabilization contracts with owners of forest land to fix the amount of taxation of qualifying forest property. Both the qualifications and amount of tax relief are set by the town. Contracts may not exceed 10 years and must be available for public inspection.

(From 10 V.S.A. Sec. 2741)

(b) A town's Board of Selectmen, without voter approval, may enter tax stabilization contracts with qualifying forest landowners. While selectmen can determine the amount of tax relief to be granted, certain state requirements for property qualifications must be satisfied:

- qualifying forest land must be at least 25 acres in size and actively managed for repeated forest crops.
- stabilization agreements must provide for rollback tax, amounting to the previous three years “tax savings”. This would be due if the land were converted to another use in violation of the contract.
- aggrieved landowners may appeal the decisions of local officials regarding applications, use value appraisal and land classification.

Tax stabilization contracts granted under this statute are subject to the general provisions of 24 V.S.A. Sec. 2741 discussed above. The difference (here) is absence of town meeting approval and the addition of certain state requirements: 25 acre parcels, rollback tax, etc.

(From 32 V.S.A. Sec. 3846)

State Land Use Tax:

(a) Qualifying owners may obtain use value (rather than fair market value) appraisal on their forest land by applying to local officials. To qualify, such land must be:

- at least 25 acres in size and actively managed for repeated forest crops.
- subject to a 10-year forest management plan

which must be annually recorded and certified by the Agency of Natural Resources. A State Current Use Advisory Board will provide a schedule of use values based on the class, type, grade and location of land together with its income-producing capability. This schedule will be used by local officials in appraising forest land each year.

Whenever such land is developed, a land use change tax amounting to 20 percent of the parcel's fair market value must be paid by the owner to the municipality. "Development" includes subdivision of land resulting in a parcel of less than 25 acres in size, construction activity not associated with forestry or logging or inappropriate timber cutting. Aggrieved landowners may appeal certain decisions of state and local officials regarding applications, appraisal and classification of property.

Heavy Cutting:

Filing of an "Intent to Cut Notification" is required if a landowner plans to conduct a heavy cut of forty acres or more, or a cut that will result in heavy cutting of eighty acres in a two-mile radius. A heavy cut is defined as "a harvest leaving a residual stocking level below the C-line as defined by the USDA Forest Service silvicultural stocking guides for the applicable timber type."

Applications and information are available at the Vermont Department of Forests, Parks, and Recreation District Offices.

(From 10 V.S.A. Sec. 2625)

